



RV Series: Communicate weight directly to your POS

Accuracy along with reliable and durable performance – the Ohaus RV Series Checkout Scale communicates directly with a POS or cash register or can be used by itself in a variety of retail applications. The Ohaus RV Series is also perfect for manual batching operations, such as controlling the weight of ingredients added to a recipe. Finally, many retailers are replacing hanging mechanical estimating scales with a simple and attractive digital scale. Whether standing alone, or connected to a computer, the Ohaus RV Series is an excellent solution for your weighing needs.

Standard Features Include:

- Capacity: 15kg (6kg available on request)
- Readability: 5g (2g available on request)
- Durable aluminum cast base
- High contrast backlit LCD display with power saving mode
- Price Computing or Weight Only displays available
- Weight Only tower display also comes with a base mounting kit
- Fast settling time for quick transaction reporting
- Dedicated ZERO and TARE key for simple and fast operation
- Software switchable communications protocols
- RS-232 Communication to the POS
- OPOS drivers available
- Automatic Zero Maintenance

RV Series Checkout Scale

Specifications

Model	RV-3211	RV-4211
Capacity x Readability	15kg x 5g	15kg x 5g
Display	Weight Only 1 Line	Price Computing 4 lines Weight, Price Per Unit, Total Price, Tare
Display Type	High contrast backlit LCD display with power saving auto shutoff	
Construction	Die cast aluminium base with rounded stainless steel platter	
Weighing Units	kg, lb	
Protocols Available	Communication protocols for most weight only and price computing POS systems	
Repeatability (std. deviation)	<1d	
Linearity and accuracy	1 d	
Corner load error / Hysteresis	1 d	
Display Indicators	Center of Zero, Net, Tare, Preset Tare	
Keyboard	2 raised tactile membrane switches: Zero and Tare	
Zero Range	±2% of full scale capacity	
Tare Range	Full capacity by subtraction	
Operating Temperature	-10° to 40°C	
Humidity Range	85% relative humidity, non-condensing	
Power	AC Adapter 9V DC / 500mA	
Pan Size	280 x 316mm	
Scale Height	Minimum Height: 55mm	
Shipping Dimensions	395mm x 445mm x 160mm	
Shipping Weight	4.7kg	
Other Features	Auto-zero tracking, filtering level	

Outline Dimensions

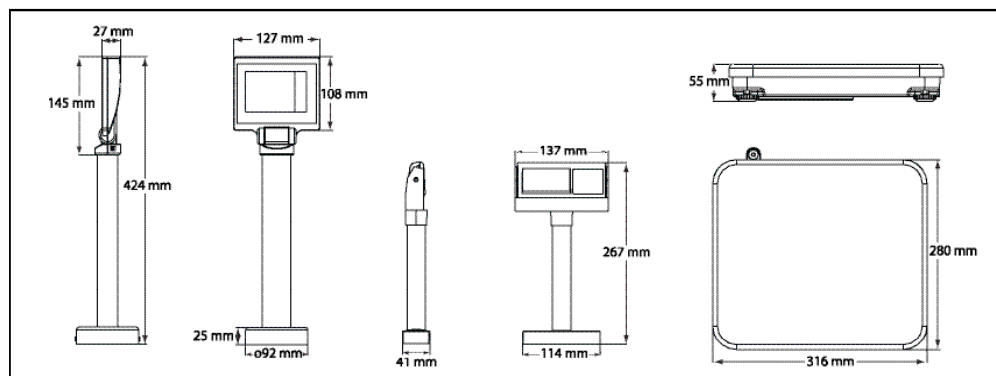

Accessories

POS communication cable
Square platter kit for flush mounting to countertop

Your Local Ohaus Dealer:

CE

ISO 9001:2000
Registered Quality Management System

www.ohaus.com

© Copyright Ohaus Corporation

