

PROVIDE THE SOLUTION



Valueweigh
Provide the Solution

VWSLT STAINLESS LIFT TOP PLATFORM SCALE

HYGIENIC CLEANING MADE SAFE AND EASY

PROFESSIONAL WEIGHING EFFORTLESS CLEANING

- 2 year manufacturer's warranty
- UK made to the highest quality standards
- Fully stainless steel washdown construction
- IP69 stainless steel OIML approved loadcells
- Stainless gas struts for effortless top plate lift
- Easy access for cleaning and maintenance
- Pit mounted or free standing with 1 or 2 ramps
- Various standard sizes and capacities
- Custom sizes and capacities available

Stainless steel gas struts ensure an effortless top plate lift which provides easy access to the specially designed wash-through base frame. With its complete stainless steel construction and fully protected IP69 rated loadcells, the UK made VWSLT can easily withstand high pressure washdown for a complete hygienic clean. The platforms are available as free standing or dormant (pit mounted) and come with optional ramps for easy access.

To reduce manual handling, the top plate lift is designed to be as effortless as possible. Once lifted, a safety support strut ensures the top plate cannot fall during cleaning. When lowered, the plate is securely held in place with captive bolts to ensure optimum strength during weighing.



Phoenix Scales Limited
34 Oldbury Road
West Bromwich
West Midlands, B70 9ED

Phone: 0845 601 7464
Email: sales@phoenixscales.co.uk

CLASS III VERIFIED

Our ISO 9001:2015 registration includes our quality system approval for Self Verification, allowing us to test and certify scales for trade use here at our factory. All VW platforms use OIML approved loadcells and are designed for Class III approval.

CUSTOMER SUPPORT

We provide the highest level of before and after sales and service support. Our technical staff are highly experienced and knowledgeable in all aspects of the weighing industry and are ready to provide support and advice on any of our products.

QUALITY

Our ISO 9001:2015 registration ensures that all of our platforms are manufactured to strict quality standards and are fully QA tested and calibrated by our highly trained engineers.

EXPERIENCE

The quality and reliability of the VW range of industrial weighing scales is the result of over 25 years of design and manufacturing experience.

RELIABILITY

The VW range is built to last. We use high quality components and will not compromise on material and build quality. All of our loadcells are OIML approved and all platforms can be Class III verified as required.

MODEL	DIMENSIONS	NO. OF GAS STRUTS
VWSLT800	800mm x 800mm	1 Gas Strut
VWSLT1010	1000mm x 1000mm	1 Gas Strut
VWSLT1210	1250mm x 1000mm	2 Gas Struts
VWSLT1212	1250mm x 1250mm	2 Gas Struts
VWSLT1512	1500mm x 1250mm	2 Gas Struts
VWSLT1515	1500mm x 1500mm	2 Gas Struts

SPECIFICATIONS

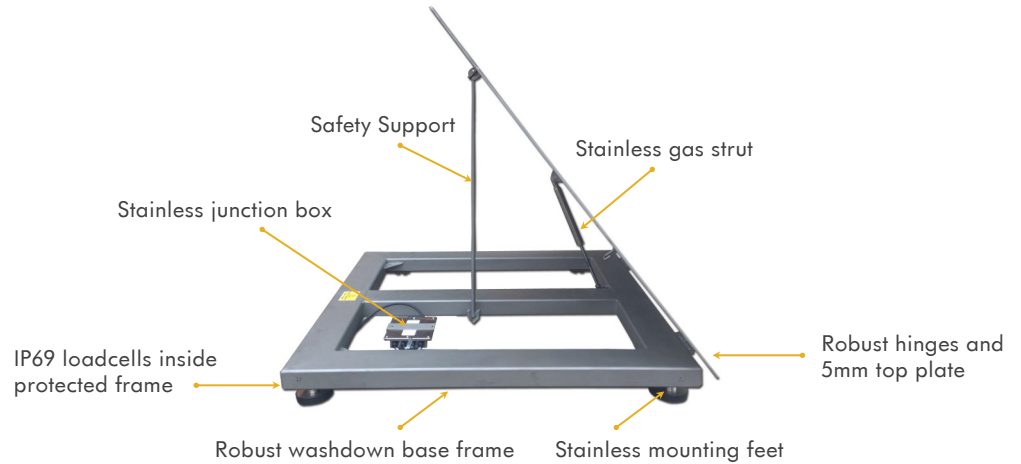

CAPACITY OPTIONS	100kg, 150kg, 300kg, 600kg, 1000kg, 1500kg, 2000kg, 3000kg
PLATFORM HEIGHT	Approx. 95mm
CONSTRUCTION	304 grade stainless steel with smooth top plate. Box section frame with 5mm top plate and stainless gas strut
FINISH	Professional - dirt trap free - glass bead blast finish
LOADCELLS	4 off Flintec OIML approved IP69 rated stainless steel loadcells
CABLE	5m of high quality cable with steel armoured braiding
FEET	Height adjustable stainless steel rubber based mounting feet
JUNCTION BOX	Stainless steel sealed junction box and summing board

OPTIONS

- 316 grade stainless steel construction
- Buffed finish (glass bead blasted as standard)
- Durbar / Split top plate
- Blue food grade stainless steel mounting feet
- Lipped edges for wheeled containers
- OIML Class III approval for trade use
- Calibration Certificate to National Standards
- Pit frame for dormant platforms
- Ramps for easy access
- Lifting Handles

